

A. チェンカッター関係 / Chain cutter mechanism / Bandabschneidereinheit / Mécanisme du coupe-chaîne / Mecanismo del cortador de cadena

< 標準用 / FOR STANDARD >

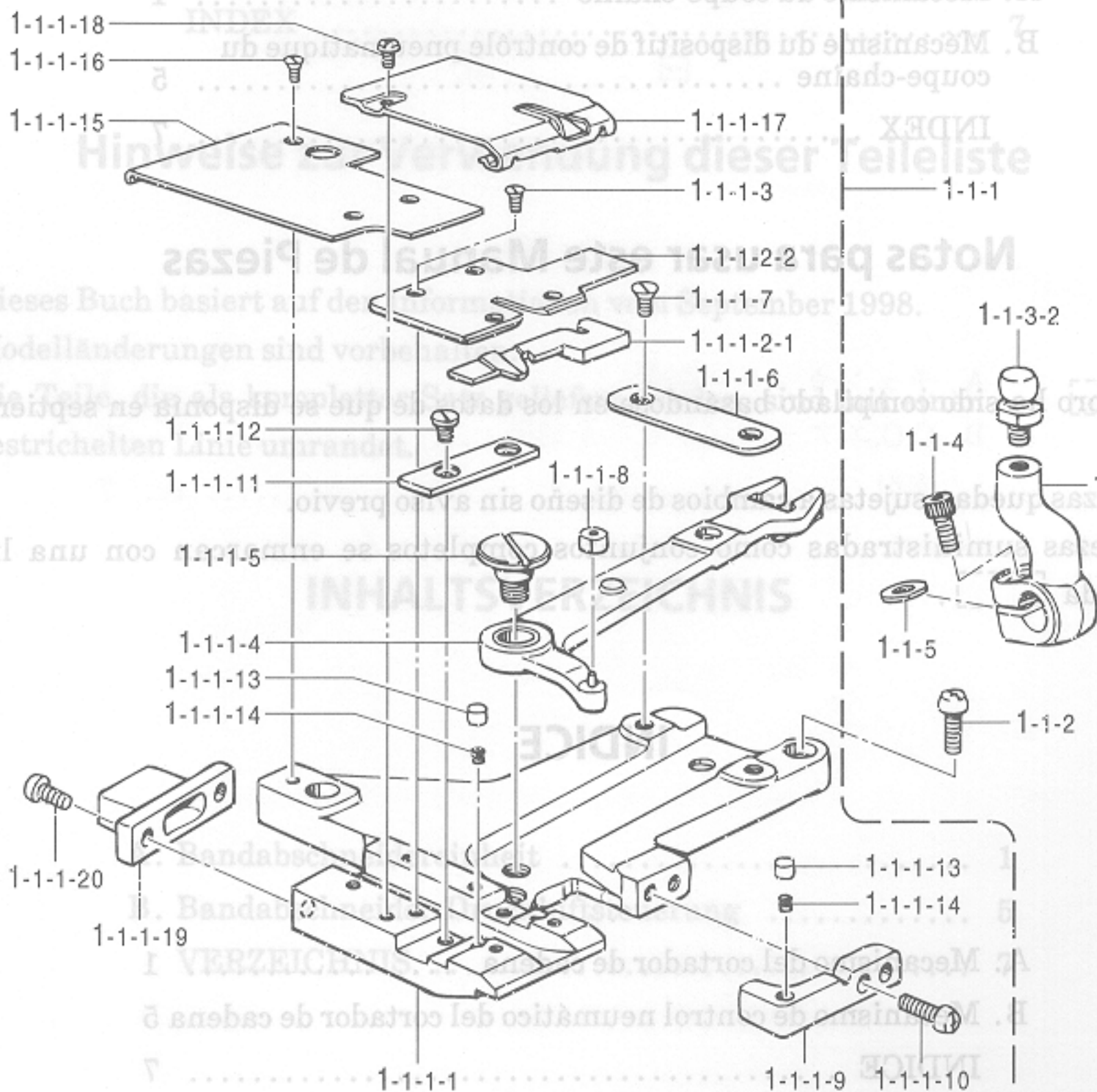
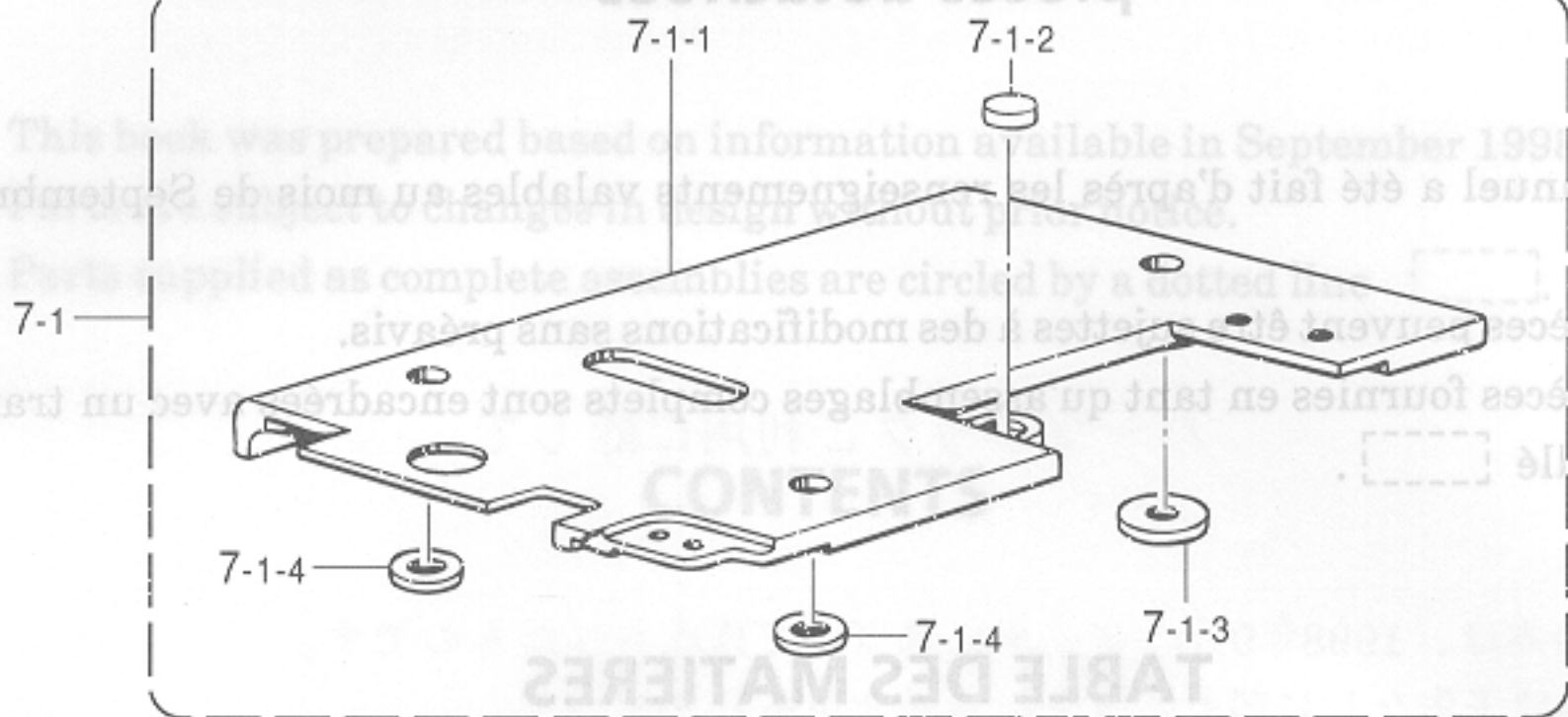

From the library of: Diamond Needle Corp

A. チェンカッター関係 / Chain cutter mechanism / Bandabschneidereinheit / Mécanisme du coupe-chaîne / Mecanismo del cortador de cadena

REF.NO.	CODE	Q'TY	ヒンメイ	NAME OF PARTS	RM
			<標準用>	<FOR STANDARD>	
1-1	S11609001	1	チェンカッタークミ	CHAIN CUTTER ASSY	
1-1-1	S11590001	1	チェンカッターソウチクミ	CHAIN CUTTER DEVISE	
1-1-1-1	S11591001	1	チェンカッタードダイ	CHAIN CUTTER BASE	
1-1-1-2	S11592001	1	メスクミ	KNIFE ASSY	
1-1-1-2-1	S11593001	1	チェンサドウハ	CHAIN MOVABLE KNIFE	
1-1-1-2-2	S11594000	1	チェンコテイハ	CHAIN FIXED KNIFE	
1-1-1-3	141542001	4	サラネジ3.18	SCREW, FLAT SM3.18	
1-1-1-4	S11595001	1	カッターレバークミ	CUTTER LEVER ASSY	
1-1-1-5	S11597001	1	ダンネジ6.35	SHOULDER SCREW, SM6.35	
1-1-1-6	S11598001	1	カッターレバーアテイタ	CUTTER LEVER WEAR PLATE	
1-1-1-7	100032004	2	サラネジ4.37	SCREW, FLAT SM4.37	
1-1-1-8	S11599001	1	カクゴマ	SLIDE BLOCK	
1-1-1-9	S11600001	1	メスアンナイ	KNIFE GUIDE	
1-1-1-10	062671212	2	ナベコ357-40X12	SCREW, PAN SM3.57-40X12	
1-1-1-11	S11601001	1	メスアテイタ	KNIFE WEAR PLATE	
1-1-1-12	100242003	2	シメネジ3.57	SCREW, SM3.57	
1-1-1-13	S11602001	3	メスオサエピン	PIN	
1-1-1-14	S11678001	3	チェンサドウハオシバネ	SPRING	
1-1-1-15	S11603001	1	チェンカッターウワカバー	CHAIN CUTTER TOP COVER	
1-1-1-16	141542001	3	サラネジ3.18	SCREW, FLAT SM3.18	
1-1-1-17	S11604000	1	メスカバーM	KNIFE COVER, M	
1-1-1-18	141544001	1	シメネジ3.18	SCREW, SM3.18	
1-1-1-19	S11605001	1	キュウニユウタイクチ	SUCTION PIPE CAP	
1-1-1-20	062670812	2	ナベコ3.57-40X8	SCREW, PAN SM3.57-40X8	
1-1-2	062681212	3	ナベコ437-40X12	SCREW, PAN SM4.37-40X12	
1-1-3	S11606001	1	クドウレバークミ	DRIVING LEVER ASSY	
1-1-3-1	S11607001	1	クドウレバー	DRIVING LEVER	
1-1-3-2	S11608001	1	クドウレバータマツギテ	JOINT	
1-1-4	018771432	1	アナボルト635-40X14	BOLT, SOCKET SM6.35-40X14	
1-1-5	155162001	1	スペーサ	SPACER	
7-1	S11565101	1	クロスプレートRクミ	CLOTH PLATE (R) ASSY	
7-1-1	S11566001	1	クロスプレートR	CLOTH PLATE, R	
7-1-2	S08646100	1	マグネット	MAGNET	
7-1-3	S08639000	1	クロスプレートパツキン	CLOTH PLATE PACKING	
7-1-4	S34200000	2	ソレノイドクツション	SOLENOID CUSHION	
7-2-1	S025080133	1	ワッシャー	WASHER, PLAIN	
7-2-2	S025080133	1	ワッシャー	WASHER, PLAIN	
7-3	S025080133	1	ワッシャー	WASHER, PLAIN	
7-3-1	S025080133	1	ワッシャー	WASHER, PLAIN	
7-3-2	S08646100	1	マグネット	MAGNET	
7-3-3	025080133	1	ワッシャー	WASHER, PLAIN	

From the library of: Diamond Needle Corp

< 向う当布付け用、厚物用 / FOR ATTACHING POCKET FACING, FOR THICK MATERIALS >

< 向う当布付け用 / FOR ATTACHING POCKET FACING >

< 厚物用 / FOR THICK MATERIALS >

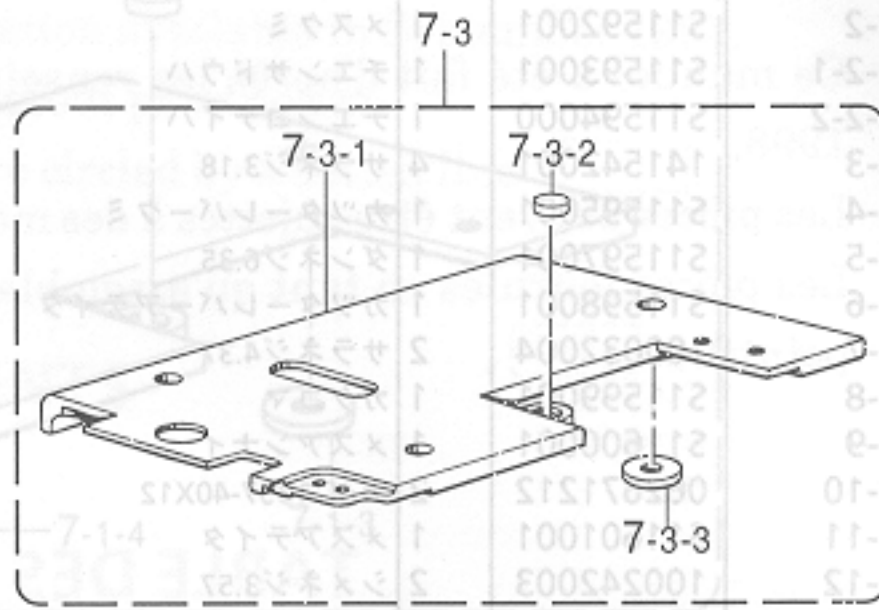
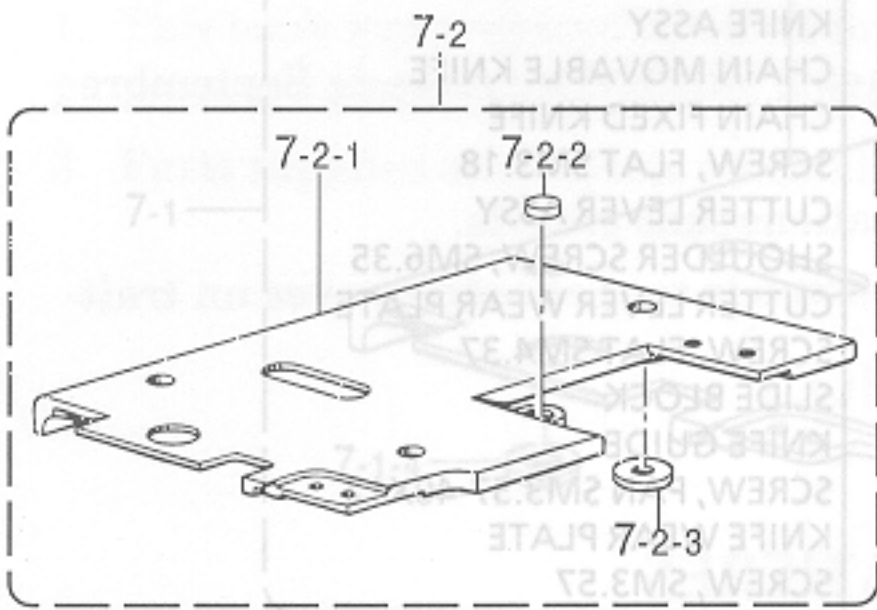

1-2

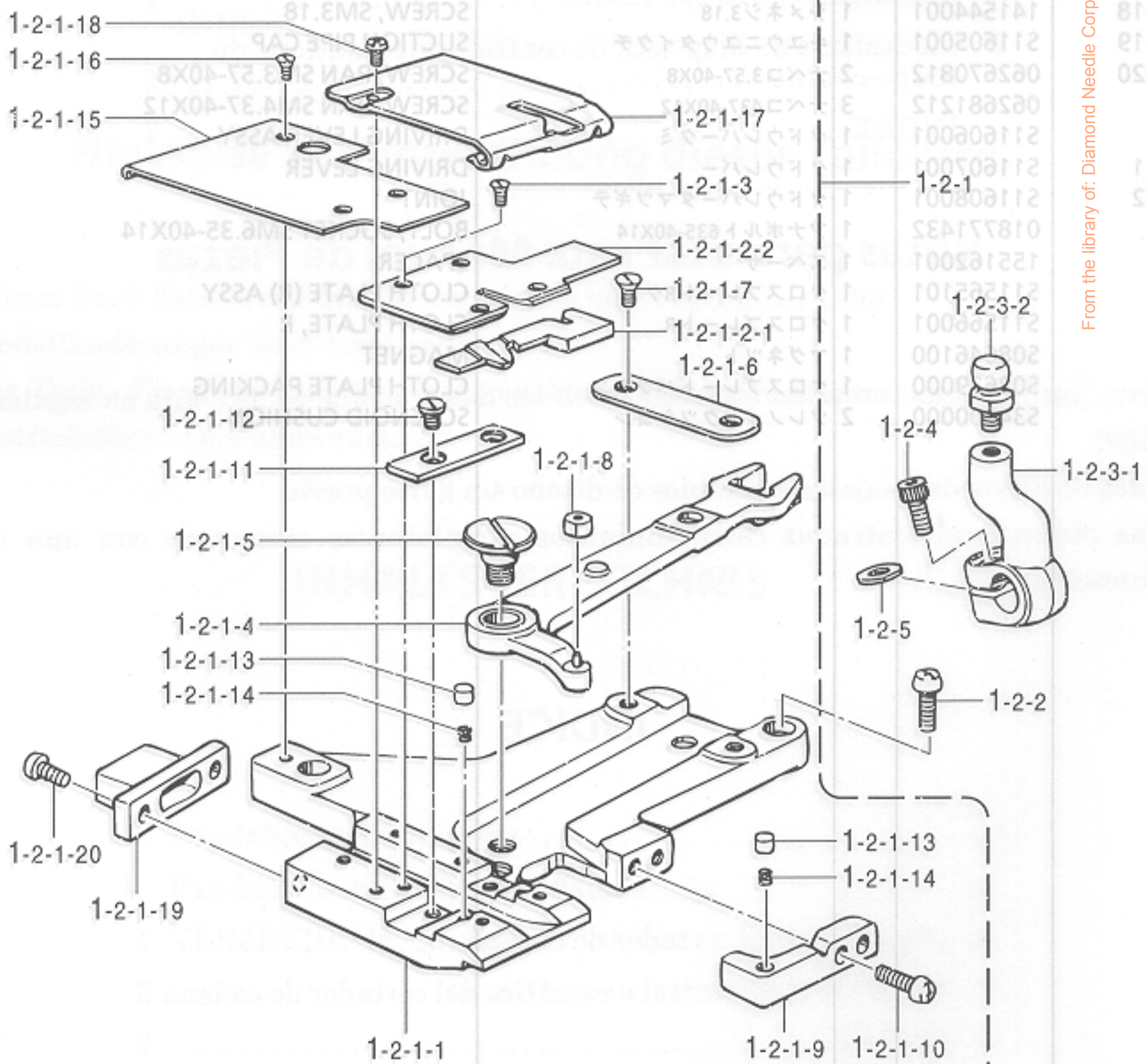

From the library of: Diamond Needle Corp

A. チェンカッター関係 / Chain cutter mechanism / Bandabschneidereinheit / Mécanisme du coupe-chaîne / Mecanismo del cortador de cadena

REF.NO.	CODE	Q'TY	ヒンメイ	NAME OF PARTS	RM
2-1	S21351001	1	<向う当布付け用,厚物用>	<FOR ATTACHING POCKET FACING, FOR THICK MATERIALS>	
2-1-1	140678000	1	ホースフキテ	AIR TUBE JOINT	
1-2	S47535001	1	チェンカッターHクミ	CHAIN CUTTER (H) ASSY	
1-2-1	S47534001	1	チェンカッターソウチHクミ	CHAIN CUTTER DEVICE ASSY	
1-2-1-1	S11591001	1	チェンカッタードダイ	CHAIN CUTTER BASE	
1-2-1-2	S11592001	1	メスクミ	KNIFE ASSY	
1-2-1-2-1	S11593001	1	チェンサドウハ	CHAIN MOVABLE KNIFE	
1-2-1-2-2	S11594000	1	チェンコテイハ	CHAIN FIXED KNIFE	
1-2-1-3	141542001	4	サラネジ3.18	SCREW, FLAT SM3.18	
1-2-1-4	S11595001	1	カッターレバークミ	CUTTER LEVER ASSY	
1-2-1-5	S11597001	1	ダンネジ6.35	SHOULDER SCREW, SM6.35	
1-2-1-6	S11598001	1	カッターレバアテイタ	CUTTER LEVER WEAR PLATE	
1-2-1-7	100032004	2	サラネジ4.37	SCREW, FLAT SM4.37	
1-2-1-8	S11599001	1	カクゴマ	SLIDE BLOCK	
1-2-1-9	S11600001	1	メスアンナイ	KNIFE GUIDE	
1-2-1-10	062671212	2	ナベコ357-40X12	SCREW, PAN SM3.57-40X12	
1-2-1-11	S11601001	1	メスアテイタ	KNIFE WEAR PLATE	
1-2-1-12	100242003	2	シメネジ3.57	SCREW, SM3.57	
1-2-1-13	S11602001	3	メスオサエピン	PIN	
1-2-1-14	S11678001	3	チェンサドウハオシバネ	SPRING	
1-2-1-15	S11603001	1	チェンカッターウワカバー	CHAIN CUTTER TOP COVER	
1-2-1-16	141542001	3	サラネジ3.18	SCREW, FLAT SM3.18	
1-2-1-17	S47533000	1	メスカバーH	KNIFE COVER	
1-2-1-18	141544001	1	シメネジ3.18	SCREW, SM3.18	
1-2-1-19	S11605001	1	キュウニユウタイクチ	SUCTION PIPE CAP	
1-2-1-20	062670812	2	ナベコ3.57-40X8	SCREW, PAN SM3.57-40X8	
1-2-2	062681212	3	ナベコ437-40X12	SCREW, PAN SM4.37-40X12	
1-2-3	S11606001	1	クドウレバークミ	DRIVING LEVER ASSY	
1-2-3-1	S11607001	1	クドウレバ	DRIVING LEVER	
1-2-3-2	S11608001	1	クドウレバータマツギテ	JOINT	
1-2-4	018771432	1	アナボルト635-40X14	BOLT, SOCKET SM6.35-40X14	
1-2-5	155162001	1	スペーサ	SPACER	
7-2	S47531001	1	<向う当布付け用>	<FOR ATTACHING POCKET FACING>	
7-2-1	S47530001	1	クロスプレートRクミ	CLOTH PLATE (R) ASSY	
7-2-2	S08646100	1	クロスプレートR	CLOTH PLATE (R)	
7-2-3	025080132	1	マグネット	MAGNET	
			ヒラザガネシヨウ8	WASHER, PLAIN S 8	
7-3	S47532001	1	<厚物用>	<FOR THICK MATERIALS>	
7-3-1	S11566001	1	クロスプレートRクミ	CLOTH PLATE (R) ASSY	
7-3-2	S08646100	1	クロスプレートR	CLOTH PLATE, R	
7-3-3	025080132	1	マグネット	MAGNET	
			ヒラザガネシヨウ8	WASHER, PLAIN S 8	
2-6	A-1	1~7-1, B-2~3	装置セット(エア)	S35510	標準用 国内用
2-6	A-1	1~7-1, B-2~3	装置セット(エア)	S36510	FOR STANDARD, FOR EXPORT
2-6	A-1	2~7-2, B-2~3	装置セットM(エア)	S47536	向う当布付け用 国内用
2-6	A-1	2~7-2, B-2~3	C DEVICE SET M(AIR)	S47536	FOR ATTACHING POCKET FACING, FOR EXPORT
2-6	A-1	2~7-3, B-2~3	装置セットH(エア)	S47537	厚物用 国内用
2-6	A-1	2~7-3, B-2~3	C DEVICE SET H(AIR)	S47537	FOR THICK MATERIALS, FOR EXPORT

From the library of: Diamond Needle Corp

B . C.C.エアコントロール関係 / Chain cutter air controller mechanism / Bandabschneider-Druckluftsteuerung / Mécanisme du dispositif de contrôle pneumatique du coupe-chaîne / Mecanismo de control neumático del cortador de cadena

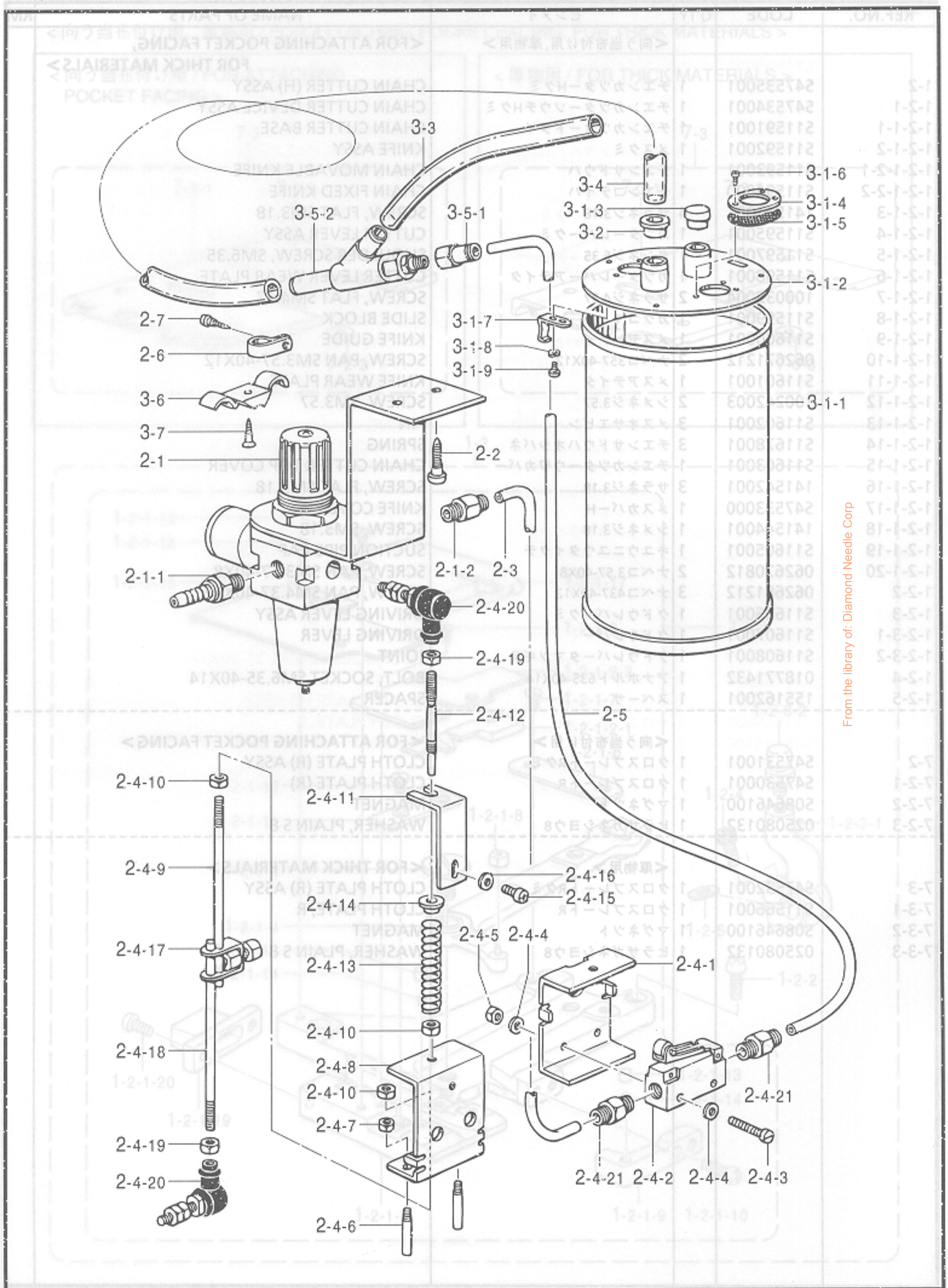

From the library of: Diamond Needle Corp

B. C.C.エアークンترول関係 / Chain cutter air controller mechanism / Bandabschneider-Druckluftsteuerung / Mécanisme du dispositif de contrôle pneumatique du coupe-chaîne / Mecanismo de control neumático del cortador de cadena

REF.NO.	CODE	Q'TY	ヒンメイ	NAME OF PARTS	RM
2	S24275001	1	C.Cコントローラークミ	CHAIN CUTTER CONTROLLER ASSY	
2-1	S21351001	1	エアユニットクミ	AIR UNIT ASSY	
2-1-1	140678000	1	ホースツギテ	AIR TUBE JOINT	
2-1-2	S01208000	1	ハーフユニオン	HALF UNION	
2-2	101118001	2	マルモクネジ4.5X20	WOOD SCREW, ROUND M4.5X20	
2-3	S21354000	1	エアチューブ	AIR TUBE, L = 950	
2-4	S21355001	1	レンカンクミ	CONNECTING ROD ASSY	
2-4-1	S21356001	1	バルブトリツケイタ	VALVE SETTING PLATE	
2-4-2	S01561000	1	メカバルブ	MICRO VALVE	
2-4-3	007402516	2	ヒラネジ4X25	SCREW, FLAT M4X25	
2-4-4	025040236	4	ヒラザガネチユウ4	WASHER, PLAIN M 4	
2-4-5	021400106	2	ナツト1シユ4	NUT, 1 M4	
2-4-6	S21357001	2	ガイドピン	PIN	
2-4-7	021400206	2	2シユナツト4	NUT, 2 M4	
2-4-8	S21358001	1	バルブサドウイタ	VALVE DIFFERENTIAL PLATE	
2-4-9	146695001	1	レンカンナカ	CONNECTING ROD, INNER	
2-4-10	021060306	3	3シユナツト6	NUT, 3 M6	
2-4-11	S21359001	1	バネチヨウセツイタ	ADJUSTING PLATE, SPRING	
2-4-12	S21360001	1	レンカンU	CONNECTING ROD, U	
2-4-13	S21361001	1	オシバネA	SPRING, A	
2-4-14	S21362000	1	バネウケ	SPRING HOLDER	
2-4-15	060400616	1	バインドM4X6	SCREW, BIND M4X6	
2-4-16	025040236	1	ヒラザガネチユウ4	WASHER, PLAIN M 4	
2-4-17	181225001	1	レンカンダキクミ	CONNECTING ROD CLAMP ASSY	
2-4-18	146695001	1	レンカンナカ	CONNECTING ROD, INNER	
2-4-19	021060306	2	3シユナツト6	NUT, 3 M6	
2-4-20	119712001	2	ジヨイントクミ	JOINT ASSY	
2-4-21	S01522000	2	ハーフユニオン	HALF UNION	
2-5	S21363000	1	エアチューブ	AIR TUBE, L = 500	
2-6	149547000	2	コードオサエ	CORD HOLDER, 4N	
2-7	031311302	2	マルモクネジ3.1X13	WOOD SCREW, ROUND M3.1X13	
<チェーン吸入管組用>				<FOR CHAIN PIPE>	
3	S36509001	1	エアークンタラークミ	AIR FILTER BOX ASSY	
3-1	147246101	1	フィルタボックスクミ	FILTER BOX ASSY	
3-1-1	147247009	1	フィルタボックス	FILTER BOX	
3-1-2	147248009	1	フィルタボックスクミフタ	FILTER BOX COVER ASSY	
3-1-3	147251009	1	ゴムセン24	RUBBER CAP, 24	
3-1-4	144625009	2	ロカモウオサエ	FILTER FLANGE	
3-1-5	147252000	2	フィルタ	FILTER	
3-1-6	060670512	6	バインド357-40X5	SCREW, BIND SM3.57-40X5	
3-1-7	111032001	3	メンイタトメイタバネL	STOPPER PLATE SPRING, L	
3-1-8	105248003	3	ザガネ	WASHER	
3-1-9	S39086001	3	ナベコ357-40X3.5	SCREW, PAN SM3.57-40X3.5	
3-2	S06946009	1	ホースクチセン	HOSE CAP	
3-3	S10876000	1	ホース300	HOSE, 300	
3-4	S06945000	1	ホース	HOSE, L = 900	
3-5	S24272000	1	ベンチユリーカンクミ	VENTURI TUBE ASSY	
3-5-1	S21390000	1	エアコネクタ	AIR CONNECTOR	
3-5-2	S21173000	1	ベンチユリーカン	VENTURI TUBE	
3-6	S10859001	1	クランプ	CLAMP	
3-7	0B1351606	1	+サラモク35X16	WOOD SCREW, FLAT M3.5X16	

From the library of: Diamond Needle Corp

- ★ 2~6ページの全商品をセットでお求めの際は下記の部品コードでご注文下さい。
- ★ When ordering all parts as a set on pages 2~6, please order by the parts no. codes below.
- ★ Für die Bestellung eines ganzen Teilesatzes auf Seite 2 bis 6 müssen die untenstehenden Teilecode-Nummern verwendet werden.
- ★ Lors de la commande de toutes les pièces des pages 2~6 en tant que jeu, utiliser les codes de pièces indiqués ci-dessous.
- ★ El pedido de todas las piezas como un juego en las páginas 2~6, se debe hacer usando los códigos de pieza indicados a continuación.

PAGE	REF.NO.	ヒンメイ	PARTS NO.	REMARKS
2~6	A-1-1~7-1, B-2~3	CC装置セット(エア)	S36510-101	標準用 国内用
2~6	A-1-1~7-1, B-2~3	C.C DEVICE SET (AIR)	S36510-102	FOR STANDARD, FOR EXPROT
2~6	A-1-2~7-2, B-2~3	CC装置セットM(エア)	S47536-001	向う当布付用 国内用
2~6	A-1-2~7-2, B-2~3	C.C DEVICE SET M (AIR)	S47536-002	FOR ATTACHING POCKET FACING, FOR EXPORT
2~6	A-1-2~7-3, B-2~3	CC装置セットH(エア)	S47537-001	厚物用 国内用
2~6	A-1-2~7-3, B-2~3	C.C DEVICE SET H (AIR)	S47537-002	FOR THICK MATERIALS, FOR EXPORT

索引 / INDEX / VERZEICHNIS

/INDEX/INDICE

CODE	REF.NO.	Page	CODE	REF.NO.	Page
S01208000	B -2-1-2	6	S21390000	B -3-5-1	6
S01522000	B -2-4-21	6	S24272000	B -3-5	6
S01561000	B -2-4-2	6	S24275001	B -2	6
S06945000	B -3-4	6	S34200000	A -7-1-4	2
S06946009	B -3-2	6	S36509001	B -3	6
S08639000	A -7-1-3	2	S39086001	B -3-1-9	6
S08646100	A -7-1-2	2	S47530001	A -7-2-1	4
	A -7-2-2	4	S47531001	A -7-2	4
	A -7-3-2	4	S47532001	A -7-3	4
S10859001	B -3-6	6	S47533000	A -1-2-1-17	4
S10876000	B -3-3	6	S47534001	A -1-2-1	4
S11565101	A -7-1	2	S47535001	A -1-2	4
S11566001	A -7-1-1	2	0B1351606	B -3-7	6
	A -7-3-1	4	007402516	B -2-4-3	6
S11590001	A -1-1-1	2	018771432	A -1-1-4	2
S11591001	A -1-1-1-1	2		A -1-2-4	4
	A -1-2-1-1	4	021060306	B -2-4-10	6
S11592001	A -1-1-1-2	2		B -2-4-19	6
	A -1-2-1-2	4	021400106	B -2-4-5	6
S11593001	A -1-1-1-2-1	2	021400206	B -2-4-7	6
	A -1-2-1-2-1	4	025040236	B -2-4-4	6
S11594000	A -1-1-1-2-2	2		B -2-4-16	6
	A -1-2-1-2-2	4	025080132	A -7-2-3	4
S11595001	A -1-1-1-4	2		A -7-3-3	4
	A -1-2-1-4	4	031311302	B -2-7	6
S11597001	A -1-1-1-5	2	060400616	B -2-4-15	6
	A -1-2-1-5	4	060670512	B -3-1-6	6
S11598001	A -1-1-1-6	2	062670812	A -1-1-1-20	2
	A -1-2-1-6	4		A -1-2-1-20	4
S11599001	A -1-1-1-8	2	062671212	A -1-1-1-10	2
	A -1-2-1-8	4		A -1-2-1-10	4
S11600001	A -1-1-1-9	2	062681212	A -1-1-2	2
	A -1-2-1-9	4		A -1-2-2	4
S11601001	A -1-1-1-11	2	100032004	A -1-1-1-7	2
	A -1-2-1-11	4		A -1-2-1-7	4
S11602001	A -1-1-1-13	2	100242003	A -1-1-1-12	2
	A -1-2-1-13	4		A -1-2-1-12	4
S11603001	A -1-1-1-15	2	101118001	B -2-2	6
	A -1-2-1-15	4	105248003	B -3-1-8	6
S11604000	A -1-1-1-17	2	111032001	B -3-1-7	6
S11605001	A -1-1-1-19	2	119712001	B -2-4-20	6
	A -1-2-1-19	4	140678000	B -2-1-1	6
S11606001	A -1-1-3	2	141542001	A -1-1-1-3	2
	A -1-2-3	4		A -1-1-1-16	2
S11607001	A -1-1-3-1	2		A -1-2-1-3	4
	A -1-2-3-1	4		A -1-2-1-16	4
S11608001	A -1-1-3-2	2	141544001	A -1-1-1-18	2
	A -1-2-3-2	4		A -1-2-1-18	4
S11609001	A -1-1	2	144625009	B -3-1-4	6
S11678001	A -1-1-1-14	2	146695001	B -2-4-9	6
	A -1-2-1-14	4		B -2-4-18	6
S21173000	B -3-5-2	6	147246101	B -3-1	6
S21351001	B -2-1	6	147247009	B -3-1-1	6
S21354000	B -2-3	6	147248009	B -3-1-2	6
S21355001	B -2-4	6	147251009	B -3-1-3	6
S21356001	B -2-4-1	6	147252000	B -3-1-5	6
S21357001	B -2-4-6	6	149547000	B -2-6	6
S21358001	B -2-4-8	6	155162001	A -1-1-5	2
S21359001	B -2-4-11	6		A -1-2-5	4
S21360001	B -2-4-12	6	181225001	B -2-4-17	6
S21361001	B -2-4-13	6			
S21362000	B -2-4-14	6			
S21363000	B -2-5	6			

From the library of: Diamond Needle Corp

★ When ordering all parts set on pages 2-6
 ★ Für die Bestellung eines ganzen Teilsatzes
 ★ Lors de la commande de toutes les pièces des
 ★ El pedido de todas las piezas como un todo

PAGE	REF. NO.
2-6	A-1-1-7-1, B-2-3
2-6	A-1-1-5-1, B-2-3
2-6	A-1-2-7-2, B-2-3
2-6	A-1-2-7-2, B-2-3
2-6	A-1-2-7-3, B-2-3
2-6	A-1-2-7-3, B-2-3